



ASK-M 72Cells

MONOCRYSTALLINE MODULE

KEY FEATURES

- ❖ High module conversion efficiency up to 19.33% by using high efficient solar cells and advanced manufacturing technology.
- ❖ Low degradation and excellent performance under high temperature and low light conditions.
- ❖ Robust aluminum frame ensures the modules to withstand wind loads up to 2400Pa and snow loads up to 5400Pa.
- ❖ High reliability against extreme environmental conditions (passing salt mist, ammonia and hail tests).
- ❖ Potential induced degradation (PID) resistance.
- ❖ Positive power tolerance of 0 ~ +3 %.

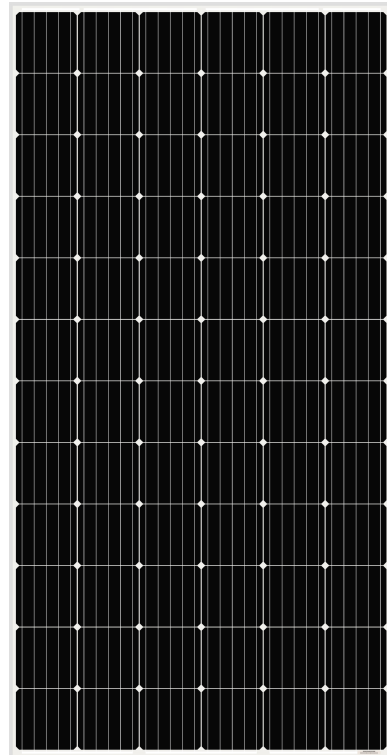

WARRANTY

- ❖ 12 years limited product warranty.
- ❖ Limited linear power warranty: 12 years 91.2% of the nominal power output, 30 years 80.6% of the nominal power output.



ELECTRICAL CHARACTERISTICS AT STC

Maximum Power (P_{max})	340W	345W	350W	355W	360W	365W	370W	375W
Open Circuit Voltage (V_{OC})	46.8V	47.0V	47.2V	47.4V	47.6V	47.8V	48.0V	48.2V
Short Circuit Current (I_{SC})	9.42A	9.50A	9.57A	9.64A	9.71A	9.78A	9.85A	9.92A
Voltage at Maximum Power (V_{mp})	38.2V	38.4V	38.6V	38.8V	39.0V	39.2V	39.4V	39.6V
Current at Maximum Power (I_{mp})	8.91A	8.99A	9.07A	9.15A	9.24A	9.32A	9.40A	9.47A
Module Efficiency (%)	17.52	17.78	18.04	18.30	18.55	18.81	19.07	19.33
Operating Temperature	-40°C to +85°C							
Maximum System Voltage	1000V DC							
Fire Resistance Rating	Class C							
Maximum Series Fuse Rating	15A							

STC: Irradiance 1000W/m², Cell temperature 25°C, AM1.5

ELECTRICAL CHARACTERISTICS AT NOCT

Maximum Power (P_{max})	253W	257W	261W	264W	268W	272W	276W	279W
Open Circuit Voltage (V_{OC})	43.3V	43.5V	43.7V	43.9V	44.1V	44.3V	44.5V	44.7V
Short Circuit Current (I_{SC})	7.63A	7.70A	7.75A	7.81A	7.87A	7.92A	7.98A	8.04A
Voltage at Maximum Power (V_{mp})	35.1V	35.3V	35.5V	35.7V	35.9V	36.1V	36.3V	36.5V
Current at Maximum Power (I_{mp})	7.21A	7.29A	7.36A	7.40A	7.47A	7.54A	7.61A	7.65A

NOCT: Irradiance 800W/m², Ambient temperature 20°C, Wind Speed 1 m/s

MECHANICAL CHARACTERISTICS

Cell type	Monocrystalline 6inch
Number of cells	72 (6x12)
Module dimensions	1956x992x40mm (77.01x39.06x1.57inches)
Weight	21kg (46.3lbs)
Front cover	3.2mm (0.13inches) tempered glass with AR coating
Frame	Anodized aluminum alloy
Junction box	IP67, 3 diodes
Cable	4mm ² (0.006inches ²), 1000mm (39.37inches)
Connector	MC4 or MC4 compatible

TEMPERATURE CHARACTERISTICS

Nominal Operating Cell Temperature (NOCT)	45°C±2°C
Temperature Coefficients of P_{max}	-0.38%/°C
Temperature Coefficients of V_{OC}	-0.29%/°C
Temperature Coefficients of I_{SC}	0.052%/°C

PACKAGING

Standard packaging	26pcs/pallet
Module quantity per 20' container	260pcs
Module quantity per 40' container	624pcs(GP)/684pcs(HQ)

ENGINEERING DRAWINGS

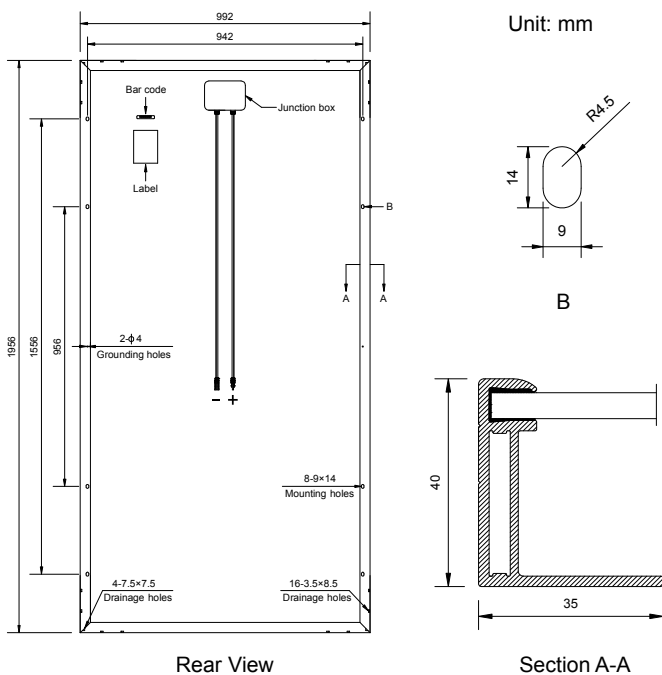

IV CURVES

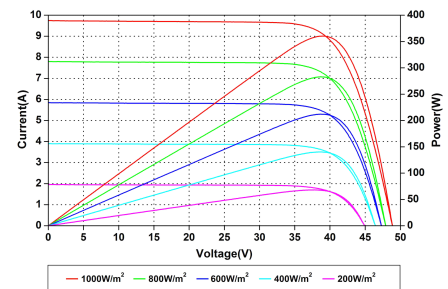

Current-Voltage and Power-Voltage Curves at Different Irradiances

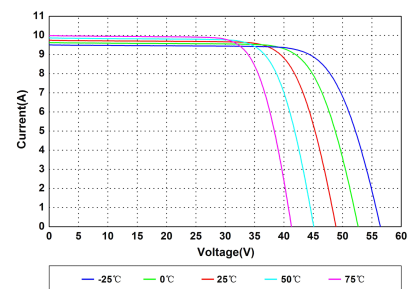

Current-Voltage Curves at Different Temperatures

Specifications in this datasheet are subject to change without prior notice.